

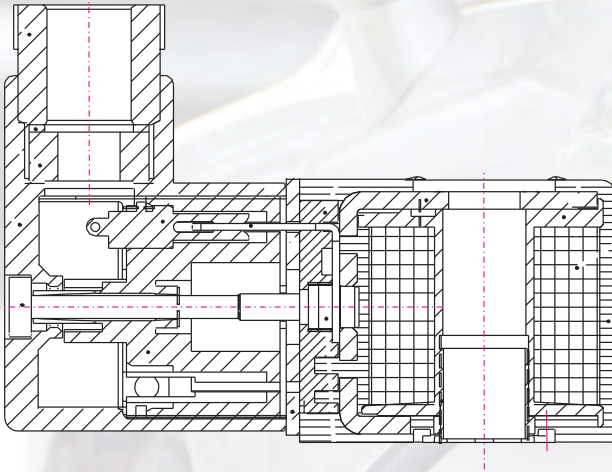

SOLENOID COILS FOR USE IN POTENTIALLY EXPLOSIVE ENVIRONMENTS



nass magnet offers components of the series “System 8” and “System 13” suitable for use in hazardous environments. Those have been tested and approved in accordance to EN/IEC 60079 and DIN VDE 0170 (as defined in directive 2014/34/EU of the European Union) by the “Phy-sikalisch-Technische Bundesanstalt” (Federal Physico-Technical Institute). Explosion prevention is granted, if the specified and matched components from the cata-logue are used.



Note
We reserve the right to make product changes without notice. For use other than general industrial pneumatics, please consult factory.





We gladly offer advice and technical support regarding the use of our products in hazardous environments, such as tank farm construction or crop processing. Please feel free to contact us.

The design of the products needs to match high quality requirements, which are being documented and tested regularly. Our portfolio consists only of sophisticated, safe and durable products.

© Backgroundpicture, small picture: ClipDealer.com



SOLENOID COIL SYSTEM 8 ATEX

Width: a) 22 mm and b) 30 mm
 Protection by encaps.: a)  II 2 G Ex mb IIC T5, T4 Gb ·  II 2 D Ex mb tb IIIC T95 °C, T130 °C Db IP65
 b)  II 2 G Ex mb IIC T6, T5, T4 Gb ·  II 2 D Ex mb tb IIIC T80 °C, T95 °C, T130 °C Db IP65
 Connection type: three-wired cable, with sleeve
 Moulding material: thermoplastic

General Data

Voltage tolerance ± 10 %
 Ambient temperature - 20 °C to + 40 °C/+ 50 °C/+ 60 °C
 Relative duty cycle 100 %
 Insulation class of insulating materials according to DIN VDE 0580 F
 Degree of protection IP 65
 Type examination certificates a) PTB 00 ATEX 2001 X
 b) PTB 03 ATEX 2018 X, IECEx PTB 04.0002X
 Imprint *nass magnet* (customer imprint possible)
 Cable length 3 m (other cable lengths on request)



22 mm

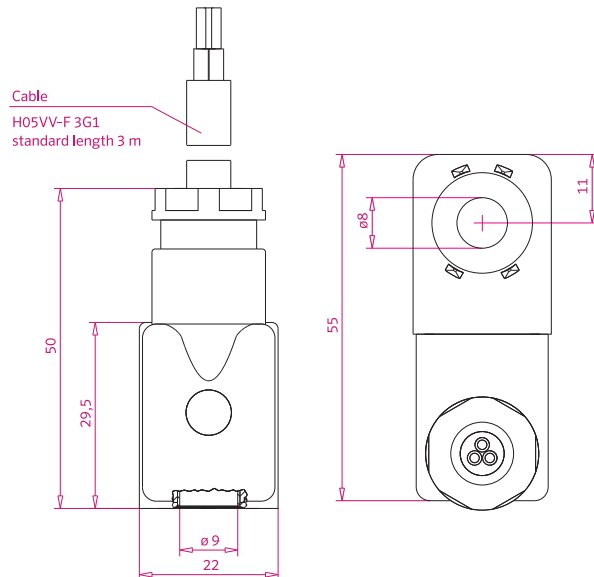

30 mm

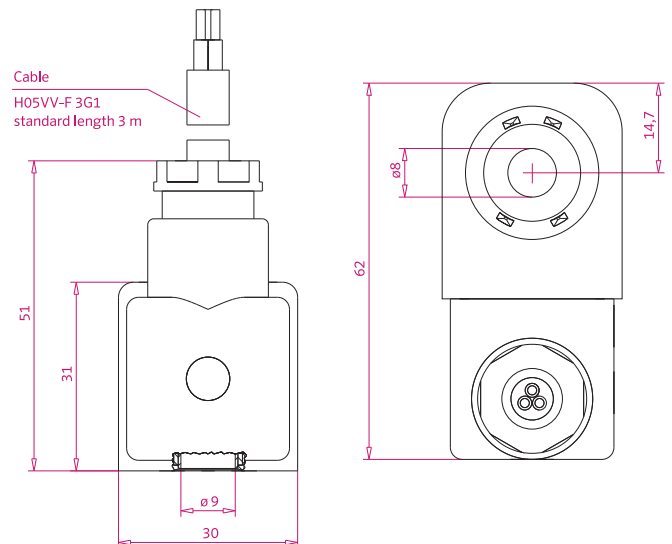

Technical Data Standard Versions, Width 22 mm

Part No.	Voltage	Frequency [Hz]	Power Level	Temperature Class
108-030-1039	24 V DC	-	1	T 5
108-030-1027	12 V DC	-	3	T 4
108-030-1028	24 V DC	-	3	T 4
108-030-0004	24 V AC	50/60	3	T 4
108-030-1029	48 V DC	-	3	T 4
108-030-0002	110 V AC	50/60	3	T 4
108-030-0003	220 V AC	50	3	T 4
108-030-0003	240 V AC	60	3	T 4

Technical Data Standard Versions, Width 30 mm

Part No.	Voltage	Frequency [Hz]	Power Level	Temperature Class
108-030-1075	24 V DC	-	3	T 6
108-030-0038	110 V AC	50/60	3	T 6
108-030-0039	230 V AC	50/60	3	T 6
108-030-1065	24 V DC	-	4	T 5
108-030-0025	110 V AC	50/60	4	T 5
108-030-0026	230 V AC	50/60	4	T 5
108-030-1052	12 V DC	-	5	T 4
108-030-1051	24 V DC	-	5	T 4
108-030-0019	24 V AC	50/60	5	T 4
108-030-0020	36 V AC	50/60	5	T 4
108-030-1053	48 V DC	-	5	T 4
108-030-0018	110 V AC	50/60	5	T 4
108-030-0021	220 V AC	50	5	T 4
108-030-0021	230 V AC	50/60	5	T 4
108-030-0021	240 V AC	60	5	T 4

Notes

- Additional approvals from national and international admission offices on request.
- Please refer to the manual prior to start of operation!

SOLENOID COIL SYSTEM 8 ATEX

Width: 30 mm
 Intrinsic safety: $\text{II 2 G Ex ia IIB/IIC T6/T4 Ga}$
 Connection type: form A - EN 175301-803-A
 Moulding material: thermoset resin

General Data

Voltage tolerance $\pm 10\%$
 Ambient temperature $-40\text{ }^{\circ}\text{C}$ to $+50\text{ }^{\circ}\text{C}/+85\text{ }^{\circ}\text{C}$
 Relative duty cycle 100 %
 Insulation class of insulating materials
 according to DIN VDE 0580 F
 Degree of protection with appropriate connector IP 65
 Type examination certificate PTB 02 ATEX 2154, IECEx PTB 08.0023
 Imprint *nass magnet* (customer imprint possible)

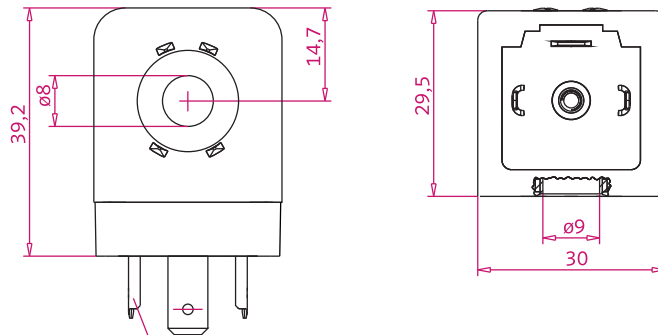
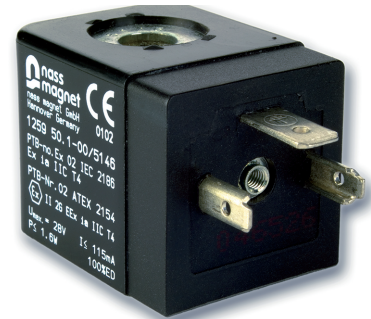

Electrical Connection
 DIN EN 175301-803-A/ISO 4400



Technical Data Standard Versions

Part No.	Ambient Temperature	Group/ max. Characteristics of Barriers	Power Level	Temperature Class
108-030-1083	- 40 °C to + 50 °C	IIC with 115 mA, 28 V DC	1	T 6
108-030-1083	- 40 °C to + 50 °C	IIB with 195 mA, 32 V DC	1	T 6
108-030-1088	- 40 °C to + 85 °C	IIC with 115 mA, 28 V DC	1	T 4
108-030-1088	- 40 °C to + 85 °C	IIB with 195 mA, 32 V DC	1	T 4

Notes

- The switching function of the intrinsically safe solenoid operator requires a minimum current of 37 mA from the safety barrier.
- The nominal operating voltage of the intrinsically safe solenoid coil is 24 V DC.
- The maximum steady-state over-temperature of the intrinsically safe solenoid coil is 18 K.
- Additional approvals from national and international admission offices on request.
- Please refer to the manual prior to start of operation!

SOLENOID COIL SYSTEM 8 ATEX WITH CONNECTOR

Width: 30 mm
 Intrinsic safety: $\text{II 2 G Ex ia IIB/IIC T6, T4 Ga}$
 $\text{II 2 D Ex t IIIC T80 °C, T130 °C Db IP65}$
 Connection type: connector for cable
 Moulding material: thermoset resin

General Data

Voltage tolerance $\pm 10 \%$
 Ambient temperature $-40 \text{ °C to } +50 \text{ °C}$
 Relative duty cycle 100%
 Insulation class of insulating materials
 according to DIN VDE 0580 F
 Degree of protection IP 65
 Type examination certificate PTB 09 ATEX 2001
 Imprint *nass magnet* (customer imprint possible)

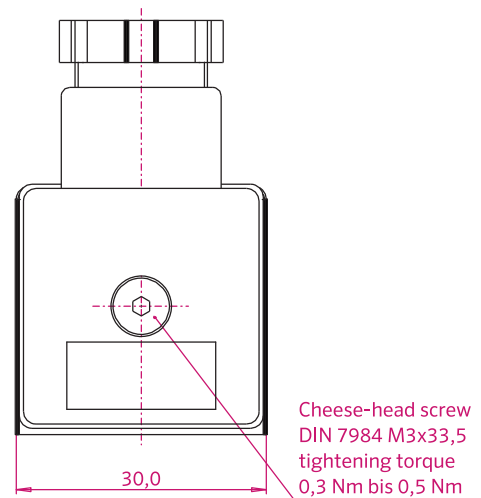
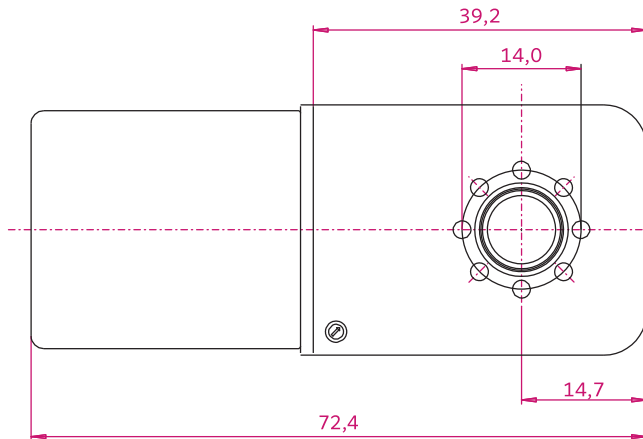





Technical Data Standard Versions

Part No.	Ambient Temperature	Group/max. Characteristics of Barriers	Power Level	Temperature Class
108-030-1160	- 40 °C to + 50 °C	IIC with 115 mA, 28 V DC	1	T 6
108-030-1160	- 40 °C to + 50 °C	IIB with 195 mA, 32 V DC	1	T 6

Notes

- The switching function of the intrinsically safe solenoid operator requires a minimum current of 37 mA from the safety barrier.
- The nominal operating voltage of the intrinsically safe solenoid coil is 24 V DC.
- The maximum steady-state over-temperature of the intrinsically safe solenoid coil is 18 K.
- Additional approvals from national and international admission offices on request.
- Please refer to the manual prior to start of operation!

SOLENOID COIL SYSTEM 8 ATEX

Width: 30 mm
 Increased degree of protection, nonincendive:  II 3 G Ex nA IIC T5 Gc
 II 3 D Ex tc IIIC T95 °C Dc IP65
 connector form A - EN 175301-803-A
 Moulding material: thermoplastic

General Data

Voltage tolerance ± 10 %
 Ambient temperature - 20 °C to + 50 °C
 Relative duty cycle 100 %
 Insulation class of insulating materials according to DIN VDE 0580 F
 Degree of protection IP 65
 Imprint *nass magnet* (customer imprint possible)

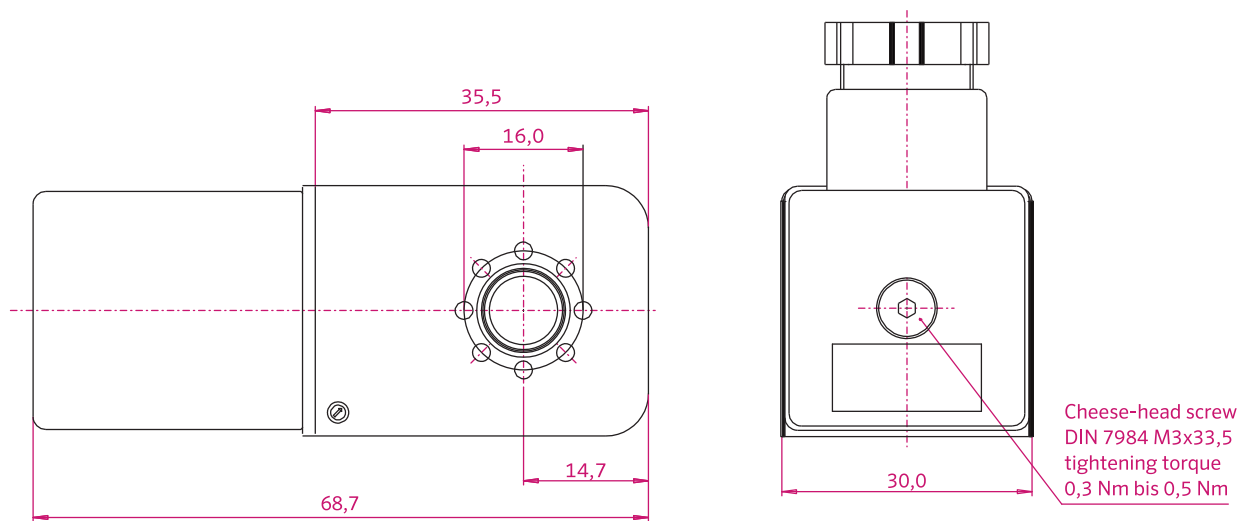





Technical Data Standard Versions

Part No.	Voltage	Frequency [Hz]	Rated Power [W]	Rated Power [VA]	Power Level	$\Delta\theta_{32}$ [K]
108-030-0761	24 V DC	-	2,1		3	32
108-030-0759	110 V AC	50		4,0	3	46
108-030-0759	110 V AC	60		3,1	3	46
108-030-0763	230 V AC	50		4,0	3	47
108-030-0763	230 V AC	60		3,1	3	47
108-030-0762	24 V DC	-	2,7		4	38

Notes

- $\Delta\theta_{32}$ [K]: steady-state over-temperature according to VDE 0580
- Please refer to the manual prior to start of operation!
- This device is only available in combination with the connector and may only be used with it.

SOLENOID COIL SYSTEM 8 ATEX

Width: 36 mm
 Protection by encaps.:  II 2 G EEx ma II T4, T5, T6
 II 2 D IP65 T80 °C, T95 °C, T130 °C
 Connection type: cable flexible at low temperatures, with ferrules
 Moulding material: thermoplastic

General Data

Voltage tolerance ± 10 %
 Ambient temperature - 50 °C to + 50 °C/+ 60 °C
 Relative duty cycle 100 %
 Insulation class of insulating materials
 according to DIN VDE 0580 F
 Degree of protection IP 65 (IP 67 on request)
 Imprint *nass magnet* (customer imprint possible)
 Cable length 3 m (other cable lengths on request)

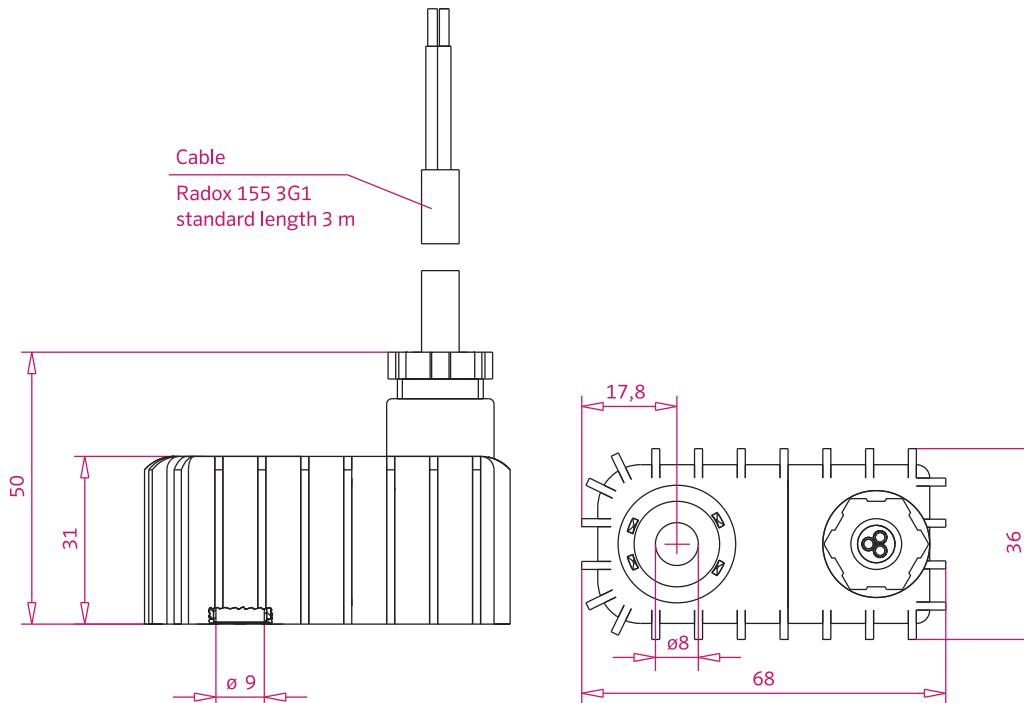



Technical Data Standard Versions

Part No.	Voltage	Frequency [Hz]	Power Level	Temperature Class
108-030-1081	24 V DC	-	5	T 4
108-030-0041	230 V AC	50/60	5	T 4

Notes

- Additional approvals from national and international admission offices on request.
- Please refer to the manual prior to start of operation!

SOLENOID COIL SYSTEM 8 CSA/FM

Width: 36 mm
 Protection by encaps.: CSA CLASS 2258 02 - process control equipment - for hazardous locations
 FM CLASS 3600, 3611, 3615, 3810 - hazardous (classified) location electrical equipment
 Approval: Ex m II T4
 Connection type: three-wired end sleeve for strands,
 thread ½-NPT for cable conduit
 Moulding material: thermoplastic

General Data

Voltage tolerance ± 10 %
 Ambient temperature - 20 °C to + 60 °C
 Relative duty cycle 100 %
 Insulation class of insulating materials
 according to DIN VDE 0580 H
 Degree of protection with appropriate cable conduit IP 65
 Type examination certificates CSA 202633, FM 3006713
 Imprint *nass magnet* (customer imprint possible)

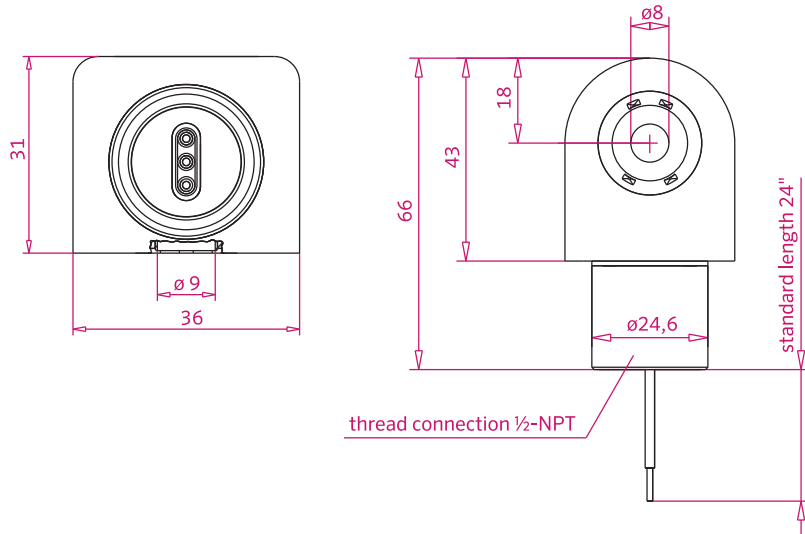



Technical Data Standard Versions

Part No.	Voltage	Frequency [Hz]	Rated Power [W] [VA]	Power Level
108-030-0965	12 V DC	-	4,5	5
108-030-0954	12 V DC	-	4,5	5
108-030-0952	24 V DC	-	4,6	5
108-030-0953	110 V AC	50	7,5	5
108-030-0955	120 V AC	60	6,8	5
108-030-0198	220 V AC	50	7,7	5
108-030-0956	240 V AC	60	6,8	5

Notes

- (*) The threaded connector is available either as a zinc-chrome-plated steel version or as a stainless steel version.
- Please refer to the manual prior to start of operation!

Hazardous Locations

Ex m II T4 and Division 1

- Specifications in accordance to CSA certificate:
 - Class I, Division 1, Groups A, B, C and D; Class II, Groups E, F and G; Class III;
 - Class I, Division 2, Groups A, B, C, D.
- Specifications in accordance to FM certificate:
 - Explosion-proof Class I, Division 1, Groups A, B, C, D, T4, Ta = 60 °C;
 - encapsulation/explosion-proof Class I, Zone 1, AEx m II T4, Ta = 60 °C;
 - dust-ignition-proof for Class II/III, Division 1, Groups E, F and G, T4, Ta = 60 °C;
 - Nonincendive Class I, Division 2, Groups A, B, C, D, T4, Ta = 60 °C
 - Suitable for Class II, III, Division 2, Groups E, F, G, T4, Ta = 60 °C

The current norms can be found in the certificates.

SOLENOID COIL SYSTEM 13 ATEX WITH TERMINAL BOX

Width: 52 mm
 Protection by encaps.: $\text{II 2 G Ex e mb IIC T4, T6 Gb}$
 $\text{II 2D Ex tb mb IIIC T130 } ^\circ\text{C, T80 } ^\circ\text{C Db IP 65, IP 67}$
 Connection type: terminal box
 Moulding material: thermoplastic

General Data

Voltage tolerance..... $\pm 10\%$
 Ambient temperature..... $-40\text{ } ^\circ\text{C to } +50\text{ } ^\circ\text{C}/+60\text{ } ^\circ\text{C}$
 Relative duty cycle..... 100 %
 Insulation class of insulating materials
 according to DIN VDE 0580..... F
 Degree of protection..... IP 65/IP 67
 Type examination certificate..... PTB 11 ATEX 2027 X
 Imprint..... *nass magnet* (customer imprint possible)

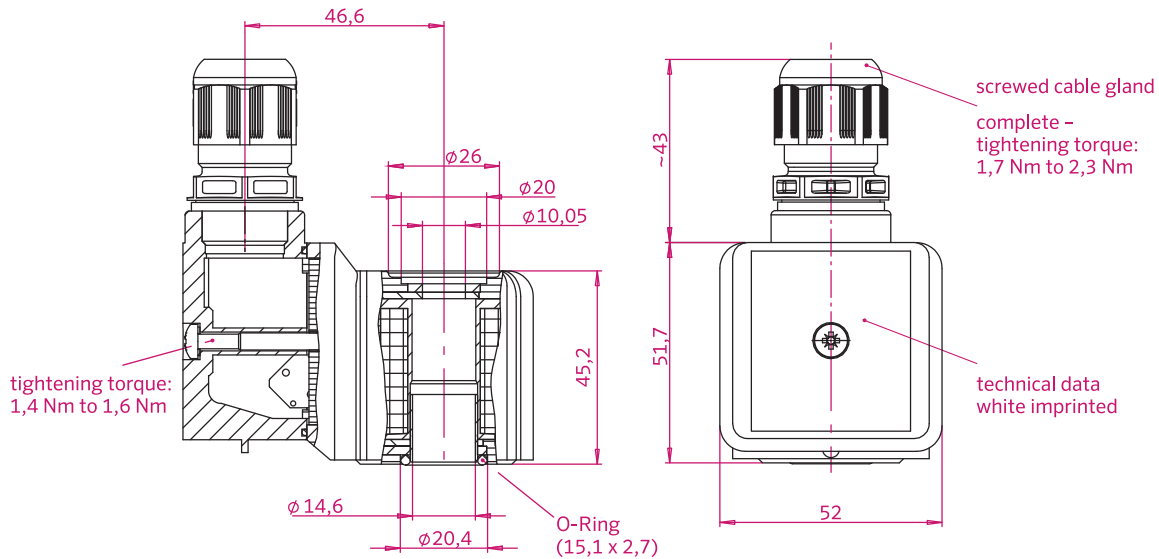



Technical Data Standard Versions

Part No.	Voltage	Ambient Temperature	Power Level	Pressure [bar]	Temperature Class
113-030-0119	24 V AC/DC	- 40 °C to + 50 °C	2	10	T 6
113-030-0318	110 V AC/DC	- 40 °C to + 50 °C	2	10	T 6
113-030-0149	230 V AC/DC	- 40 °C to + 50 °C	2	10	T 6
113-030-0103	24 V AC/DC	- 40 °C to + 60 °C	3	10	T 4
113-030-0118	110 V AC/DC	- 40 °C to + 60 °C	3	10	T 4
113-030-0094	230 V AC/DC	- 40 °C to + 60 °C	3	10	T 4

Notes

- The increased degree of protection IP 67 can be realized with a exhaust protector for the mounting of the solenoid coil.
- The solenoid coils are equipped with a rectifier and therefore independent with regard to the supply frequency.
- Additional approvals from national and international admission offices on request.
- Please refer to the manual prior to start of operation!

SOLENOID COIL SYSTEM 13 ATEX

Width: 36 mm
 Protection by encaps.:  II 2 G Ex mb II T6, T5, T4 Gb
 II 2 D Ex tb IIIC T80 °C, T95 °C T130 °C Db IP65
 Connection type: three-wired cable, with ferrules
 Moulding material: thermoplastic

General Data

Voltage tolerance	± 10 %
Ambient temperature	- 20 °C to + 40 °C/+ 50 °C
Relative duty cycle	100 %
Insulation class of insulating materials according to DIN VDE 0580	F
Degree of protection	IP 65
Type examination certificates	PTB 03 ATEX 2086 X, IECEx PTB 05.0005X
Imprint	<i>nass magnet</i> (customer imprint possible)
Cable length	3 m (other cable lengths on request)

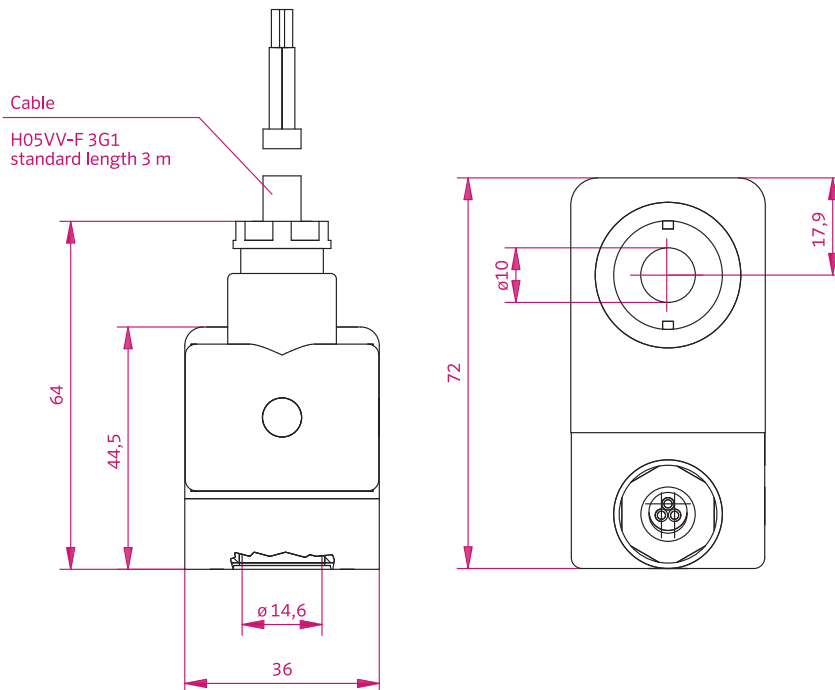

Technical Data Standard Versions

Part No.	Voltage	Frequency [Hz]	Power Level	Temperature Class
113-030-0264	24 V DC	-	2	T 5
113-030-0003	24 V AC	-	3	T 4
113-030-0004	110 V AC	50/60	3	T 4
113-030-0002	230 V AC	50/60	3	T 4

Notes

- Please note that the power levels of System 8 and System 13 differ regarding the controllable pneumatic nominal data. A combination of solenoid coils and armature systems of the two different series is not possible.
- Additional approvals from national and international admission offices on request.
- Please refer to the manual prior to start of operation!

SPECIAL ADVICE REGARDING EX-SOLENOID COILS

Note: The proportions of the solenoid coils displayed in the images on this page do not represent the actual proportions.



Width: 22 and 30 mm
Protection by encaps.: Ex II 2 G Ex mb IIC T5, T4 Gb, Ex II 2 D Ex mb tb IIIC T95 °C, T130 °C Db IP65 (22 mm); Ex II 2 G Ex mb IIC T6, T5, T4 Gb, Ex II 2 D Ex mb tb IIIC T80 °C, T95 °C, T130 °C Db IP65 (30 mm)
Connection type: three-wired cable



Width: 30 mm
Intrinsic safety: Ex II 2 G Ex ia IIB/IIC T6/T4 Ga
Connection type: connector form A



Width: 30 mm
Intrinsic safety: Ex II 2 G Ex ia IIB/IIC T6, T4 Ga; Ex II 2 D Ex t IIIC T80 °C, T130 °C Db IP65
Connection type: connector for cable



Width: 30 mm
Increased degree of protection, nonincendive: Ex II 3 G Ex nA IIC T5 Gc; Ex II 3 D Ex tc IIIC T95 °C Dc IP65
Connection type: connector form A



Width: 36 mm
Protection by encaps.: Ex II 2 G EEx ma II T4, T5, T6; Ex II 2 D IP65 T80 °C, T95 °C, T130 °C
Connection type: cable flexible at low temperatures

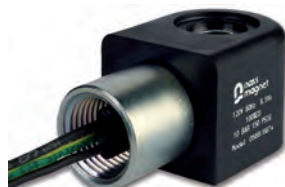

Width: 36 mm
Protection by encaps.: CSA CLASS 2258 02, FM CLASS 3600, 3611, 3615, 3810
Approval: Ex m II T4
Connection type: flying leads, thread 1/2-NPT



Width: 52 mm
Protection by encaps.: Ex II 2 G Ex e mb IIC T4, T6 Gb; Ex II 2 D Ex tb mb IIIC T130 °C, T80 °C Db IP 65, IP 67
Connection type: terminal box



Width: 36 mm
Protection by encaps.: Ex II 2 G Ex mb II T6, T5, T4 Gb; Ex II 2 D Ex tb IIIC T80 °C, T95 °C T130 °C Db IP65
Connection type: three-wired cable

The mentioned technical data are valid for the indicated standard voltages. Other voltages are available on request. The perfect function of these solenoid coils and the respective components shown in this catalogue will be guaranteed for a winding at operating temperature, maximum ambient temperature and maximum voltage tolerance. The steady-state over-temperature is reached with valve bodies in plastic.



Encapsulated and Intrinsically Safe Solenoid Operators

These solenoid operators were tested by the Physikalisch-Technische Bundesanstalt (PTB) according to the directive 94/9/EC. They are generally suited for single and block assembly. Specific instructions and remarks for safe operation can be found in the respective operating instructions. Explosion protection can only be realized if the respective components shown in this catalogue are used. The maximum operating pressure for the armature/valve system is 12 bar.

Solenoid Operators with Increased Protection, Non-Igniting

These solenoid operators were tested by *nass magnet* according to the directive 94/9/EC. Explosion protection can only be realized if the respective components shown in this catalogue are used. The maximum operating pressure for the armature/valve system is 12 bar.

Explosion Requirement

Flammable Sources

hot surfaces
flames and hot gases
mechanically/electrically produced sparks
equalising currents
static electricity
lightning stroke

Inflammable Substances

Gases and dusts arising from flammable liquids and solid materials, and existing in the right incendive concentration

Oxygen Sources

air (21 % oxygen)
pure oxygen
oxygen releasing compounds
(potassium permanganate and others)



The classification of potentially explosive environments is based on directives of the European Parliament and the Council of the European Union. Those directives have been transferred to European and national legislation. Explosion protection – both Europe-wide and worldwide – is defined by the following committees:

- European committee for electrotechnical standardization – CENELEC
- International electrotechnical committee – IEC

Zone Classification of Hazardous Locations

Ex-zones specify locations with a dangerous and potentially explosive atmosphere based on the following criteria:

Zone 0 for gases: present permanently or on a long-term base (more than 1.000 hours per year); this includes the inside of a tank container of a vehicle transporting hazardous goods, for instance.

Zone 1 for gases: occasionally present (10 to 1.000 hours per year); this includes the filling area between the subsurface tank of a gas station and the tank wagon, for instance.

Zone 2 for gases: present only on rare occasions and on a short-term base (less than 10 hours per year); this includes the drive-through area in between the fuel dispensers of a gas station, for instance.

Zone 20 for dust: present permanently or on a long-term base (more than 1.000 hours per year) in a cloud-like fashion; this includes the inside of the silo of a flour mill, for instance.

Zone 21 for dust: present occasionally through the raising of settled dust (10 to 1.000 hours per year); this includes the outer filling area of the silo of a flour mill, for instance.

Zone 22 for dust: present only on rare occasions and on a short-term base (less than 10 hours per year); this includes minor dust debris on pipe plugs, for instance.



Correlation: Zone/Category

The device requirements are specified in categories. These categories are assigned to the following zone classification

Zone Classification	DUST	Device Requirements	DUST
GAS		GAS	
Zone 0	Zone 20	Category 1G	Category 1D
Zone 1	Zone 21	Category 2G	Category 2D
Zone 2	Zone 22	Category 3G	Category 3D

A higher-class device requirement is possible. A solenoid coil of the device category 2G may be used in zone 2, for example. The device requirement specifies the efficiency of individual protection measures within an electrical piece of equipment.

Classification of flammable substances in groups and temperature classes (based on the max. acceptable surface temperature)

TEMPERATURE CLASS	T1 (450 °C)	T2 (300 °C)	T3 (200 °C)	T4 (135 °C)	T5 (100 °C)	T6 (85 °C)
EXPLOSION GROUP IIA	Acetone (540 °C)	n-Butane (365 °C)	Gasoline (220 bis 300 °C)	Acetaldehyde (140 °C)		
	Ammonia (630 °C)	n-Butyl Alcohol (340 °C)	Diesel Fuel (220 bis 300 °C)			
	Benzol (555 °C)		Plane Fuel (220 bis 300 °C)			
	Ethane (515 °C)		Heating Oil (220 bis 300 °C)			
	Acetic Acid (485 °C)					
	Carbon Oxide (605 °C)					
	Methanol (455 °C)					
	Propane (470 °C)					
IIB	City Gas (560 °C)	Ethyl Alcohol (425 °C)	Ethyl Glycol (335 °C)	Ethyl Ether (180 °C)		
		Ethylene (425 °C)	Hydrogen Sulfide (270 °C)			
IIC	Hydrogen (560 °C)	Acetylene (305 °C)				Carbon Disulfide (95 °C)

Explosion-Proof Type (Abstract)

The European Standard EN 60079-0 comprises generic regulations for construction type and concurrent validation of electrical equipment to be applied on hazardous areas. It refers to further standards, which e.g. define the ignition protection type. The actual ignition protection type is distinctly coded on the equipment.

Name	Standard	Remarks
Encapsulation of oil (o)	EN 60079-7	Regarding the explosion-proof type <i>encapsulation of oil</i> , the device or part of it are separated from the explosive atmosphere.
Encapsulation of overpressure (p)	EN 60079-2	An explosion-proof gas being under overpressure (min. 0,5 mbar) shields the ignition source and avoids the penetration of the surrounding atmosphere.
Encapsulation of sand (q)	EN 60079-5	The fine-grain filling material shields the ignition source. Orderly used, an arc created inside may not ignite the ex-atmosphere surrounding the body.
Pressure-resistant encapsulation (d)	EN 60079-1	In case of ignition inside the encapsulation, the body must resist the pressure, and a transmission of the <i>inner</i> explosion to the outside must be excluded.
Increased safety (e)	EN 60079-7	The explosion-proof type (e) is only valid for equipment or parts of it which, under normal circumstances, do neither create sparks nor arcs, do not reach hazardous temperatures and the nominal voltage of which does not exceed 11 kV.
Intrinsic safety (i)	EN 60079-11	The energy inside the circuit is limited to values which do not allow inadmissibly high temperatures and/or sparks respectively arcs.
<i>Nonincendive (n)</i>	EN 60079-15	Simplified application of the other explosion-proof types for zone 2
Protection by encapsulation (m)	EN 60079-18	The ignition source is embedded into a sealing compound in such a way that it cannot ignite a hazardous explosive atmosphere.



IP-Degree of Protection

GRADE	Against contact and of foreign objects	Against penetration of water
0	No protection	No protection
1	Protection against big foreign objects	Vertically falling water drops must not have any damaging effect
2	Degree of protection against contact with and penetration of foreign objects > 12 mm	Water drops falling in any angle up to 15 °C to the perpendicular must not have any damaging effect.
3	Degree of protection against contact with and penetration of foreign objects > 2,5 mm	Water drops falling in any angle up to 60° C to the perpendicular must not have any damaging effect.
4	Protection against granular foreign objects > 1 mm	Water splashing against work equipment from all directions must not have any damaging effect.
5	Protection against penetration of dust	A water jet from a nozzle being brought onto the work equipment must not have any damaging effec.
6	Protection against dust entrance	In case of temporary flooding, e g in case of heavy seas water must not penetrate into the work equipment in harmful quantities.
7		If the work equipment is plunged into water under stipulated conditions of pressure and time (lowest part at least 1 m under water column for 30 minutes), water must not penetrate into it.
8		If the work equipment is plunged into water with a predefined.

Attention!

The proven IP-degree of protection is a substantial part of the regulatory initiation of Ex-solenoid coils. Modifications of any kind, such as the shortening or the improper extension of cables, reboring, additional or wrong labeling will cause the license of the modified product to expire. Initiation of machines or constructions with modified Ex-solenoid coils is forbidden without exception.

WORK EQUIPMENT IDENTIFICATION

Electric utilities inside of the European Union need to be in accordance with the relevant regulations. If a manufacturer matches those requirements, the respective device will be marked with the CE-symbol.

For the explosion protection according to ATEX (ATmosphère EXplosibles as specified by directive 2014/34/EU), this mark will be extended by the number of the notifying body. The “Physikalisch-Technische Bundesanstalt” (Federal Physico-Technical Institute), for example, has the number 0102. Furthermore, the year of production and the constructive safety level need to be indicated on the device.

Intrinsically safe work equipment may, as an example, bear the following identification:

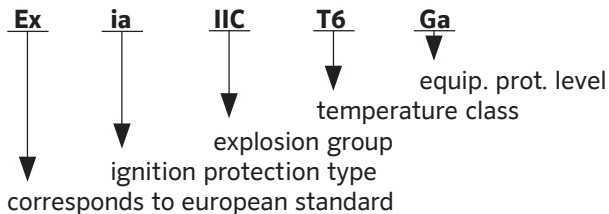

According to the directive EN 60079-0 this identification is as follows:

PTB 02 ATEX 2154 X

PTB: notified body

02: year of examination

ATEX: according to directive 2014/34/EU

2154: current number of type-examination certificate

X: the certificate is subject to special conditions

According to the ATEX directive intrinsically safe work equipment is then identified as follows:

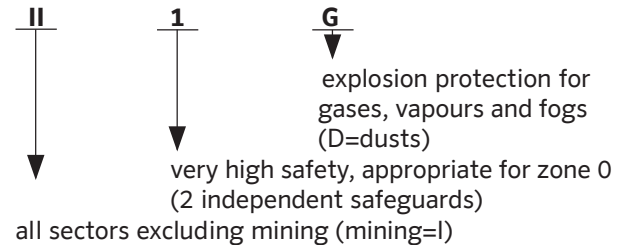

The device category of the pertinent work equipment is put in round brackets:

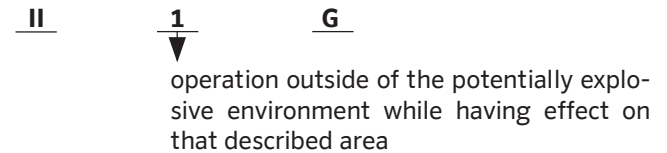

In summary, intrinsically safe work equipment is provided with the following complete identification:

⊕ II 1 G Ex ia IIC T6 Ga

Analogously, the complete identification of pertinent work equipment is as follows:

II (1) G [Ex ia] IIC